

Unlock Next Generation 3D Software: Getting Started with Parasolid

Insights from Siemens Digital Industries
Software and AMC Bridge

- How Parasolid's 1000+ modeling API's enable high-precision, scalable 3D applications
- Proven strategies for accelerating development and reducing complexity using PLM Components
- Introduction of AMC Bridge as Trusted Parasolid implementation partner
- Real-world success stories from AMC Bridge's 20+ Parasolid-based projects

- How Parasolid's 1000+ modeling API's enable high-precision, scalable 3D applications
- Proven strategies for accelerating development and reducing complexity using PLM Components
- Introduction of AMC Bridge as Trusted Parasolid implementation partner
- Real-world success stories from AMC Bridge's 20+ Parasolid-based projects

Parasolid is the market leading **geometric modeling kernel** developed by Siemens

What it is

A **math engine** used by **3D modeling applications** for defining the shape of a **digital twin** with precise, closed geometric volumes to mimic the physical characteristics of a real-world object

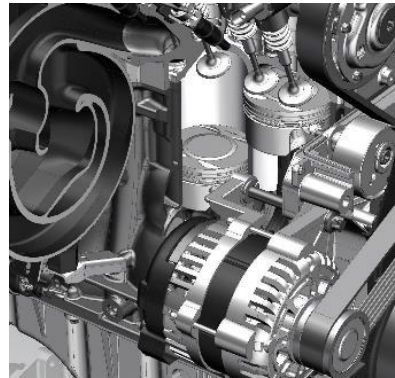

$$P(u, v) = \frac{\sum_{i=0}^{n-1} \sum_{j=0}^{m-1} b_i(u)b_j(v)w_{ij}V_{ij}}{\sum_{i=0}^{n-1} \sum_{j=0}^{m-1} b_i(u)b_j(v)w_{ij}}$$

Why it matters

It ensures **accuracy, robustness,** and **reliability** across every operation on solid and surface geometry

Applications can **focus on user and industry-specific workflows**, while Parasolid handles all geometry computation

Parasolid-based software underpins products in nearly every manufacturing sector, from **aerospace** to **consumer goods**



Aircraft structures, engines and fuel components, jigs and fixtures

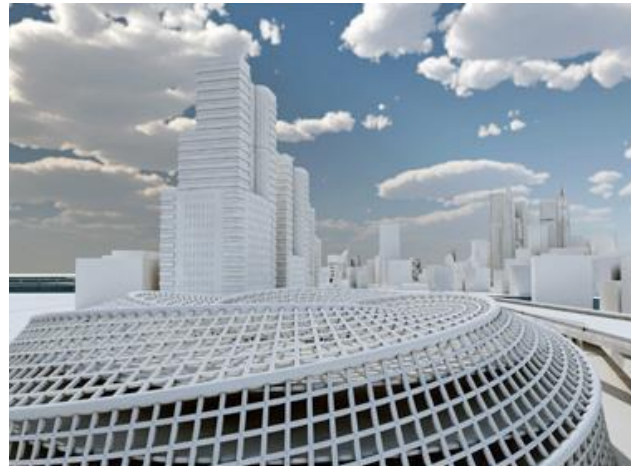

Complex, organic, or specialized building components



Phones, furniture, sport equipment

Parasolid is the market leading **geometric modeling kernel** developed by Siemens

Design

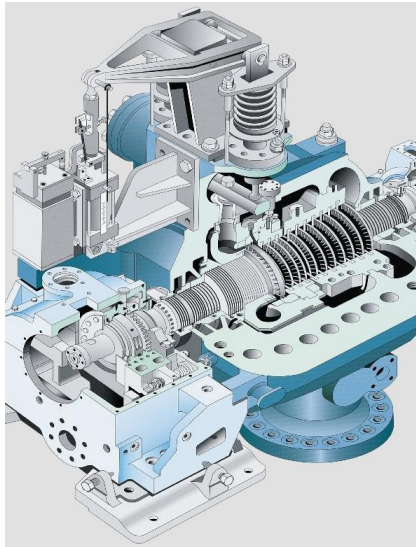

Create geometric models of any size/complexity in any industry and reuse the 3D model to create new design variations

Simulate



Optimize the real-world product by analyzing the 3D model for structural stress and strain, fluid flow, acoustics etc.

Manufacture



Use the 3D model to create manufacturing tools and instructions for machine tools, 3D printers and robots

200+
customers

70%
estimated market
penetration

10 million+
active design engineers

CAD



Simulation



Manufacturing

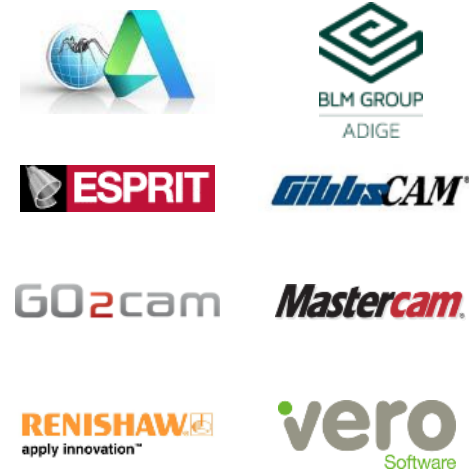

AEC



Why Parasolid - technical highlights



- **1000+ modelling features** – ideal foundation for innovative 3D application development
- **Convergent modelling** – classic boundary representation and mesh data fully integrated in the same model structure
- **Support for all main operating systems/CPU architectures** whether deployed on the cloud, desktop, tablet or smart phone. Python binding and Web Assembly build available
- **Open, published XT format** – estimated 45% of world's 3D CAD models in XT format
- **Complementary tools for data repair and translation**, granting maximum compatibility with other main CAD formats

Why Parasolid – business advantages

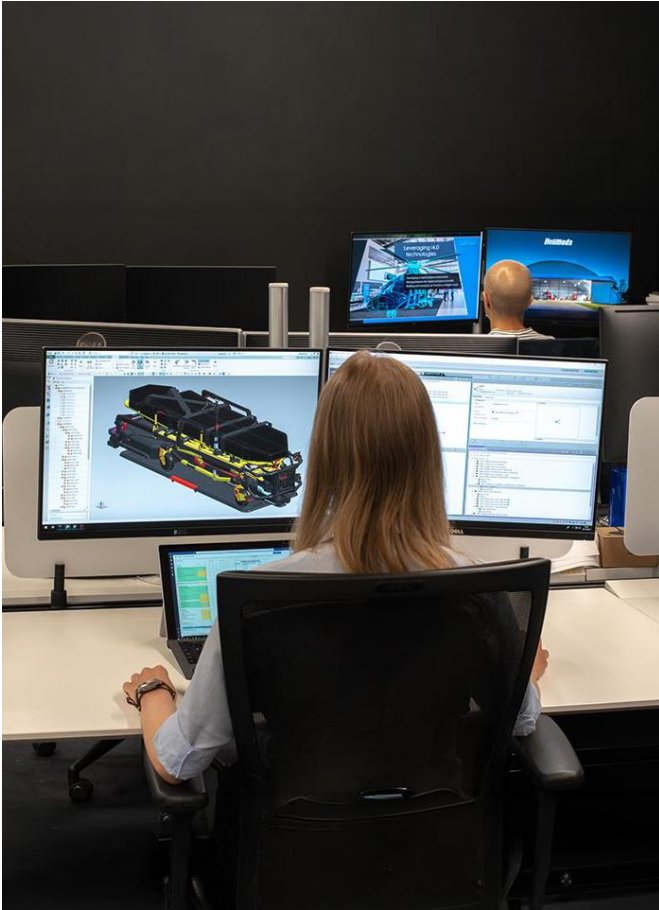

- **Reduce development costs and risks** by using an industry-proven 3D modeling solution
- **Plug and play** – can be embedded off-the-shelf, without any maintenance effort
- **Corporate standard** for Siemens’s Design Center®, Simcenter® and Teamcenter®, offered in the open market with the same functionalities and same support
- **Continuous innovation** in the past 40 yrs in Cambridge, UK. Built on our proven people, processes and technology
- **Scalability** – integrated by startups and established enterprises alike
- **Efficient release process** – new functionalities, API changes and backward compatibility thoroughly documented to ensure successful upgrades, twice a year

- How Parasolid's 1000+ modeling API's enable high-precision, scalable 3D applications
- Proven strategies for accelerating development and reducing complexity using PLM Components
- Introduction of AMC Bridge as Trusted Parasolid implementation partner
- Real-world success stories from AMC Bridge's 20+ Parasolid-based projects

Siemens Parasolid's **development** and **technical support teams** work in **synergy**, guiding developers through **setup, usage** and **troubleshooting** of the kernel

- Since its **first version in 1988**, Parasolid is developed and maintained in our offices in **Cambridge, UK**
- **Parasolid's component deliverables for all integrators** include:
 - Comprehensive **functional overview**
 - Comprehensive **API documentation**, listing all available interfaces and data structures, method signatures, input/output parameters, error handling and lifecycle behavior
 - **Example code** demonstrating how to use the SDK's APIs in a typical implementation scenario
 - **Prototyping environment** helping visualize the result of modeling operations
- Siemens Parasolid's technical support is available for any product related enquiries during and after integration
- In-person product training is also available on request

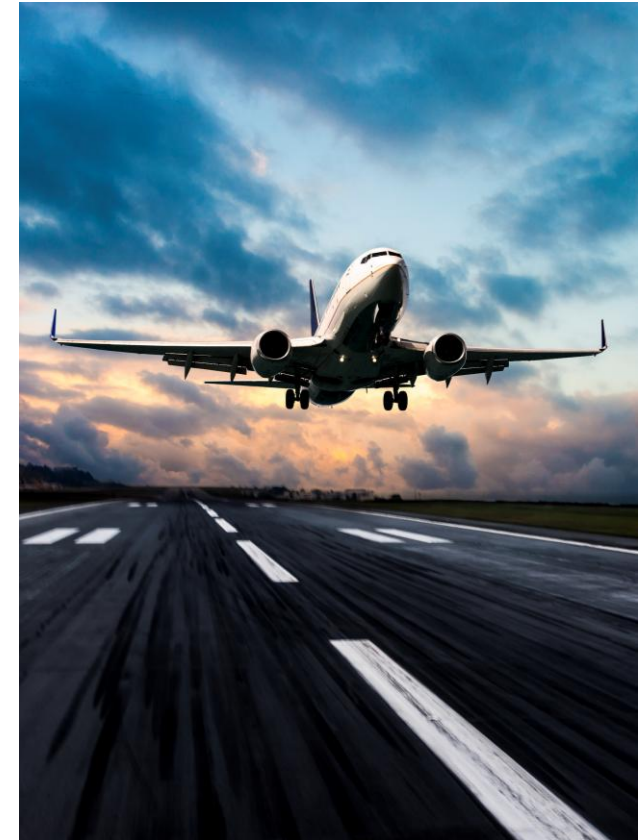

AMC Bridge is a trusted integrator, providing extensive PLM Components expertise and **further accelerating time-to-market for software vendors**

- **In-depth knowledge of the use of components** – reduce the perceived “energy barrier” that can be the learning curve of a very comprehensive library
- Hands-on **expertise** and **proven** integration **patterns**
- **Streamline development efforts** with architecture guidance, testing and deployment support
- **Performance** tuning
- **Custom development**
- **Typical scenarios:**
 - Build a completely new product around Parasolid
 - Migrating from a different kernel
 - Boosting an existing product



- How Parasolid's 1000+ modeling API's enable high-precision, scalable 3D applications
- Proven strategies for accelerating development and reducing complexity using PLM Components
- Introduction of AMC Bridge as Trusted Parasolid implementation partner
- Real-world success stories from AMC Bridge's 20+ Parasolid-based projects

25+

Years of experience

650+

Technical Staff

350+

Clients

96%

Customer Return

99%

of Clients say they would recommend AMC Bridge

Sample Clients:



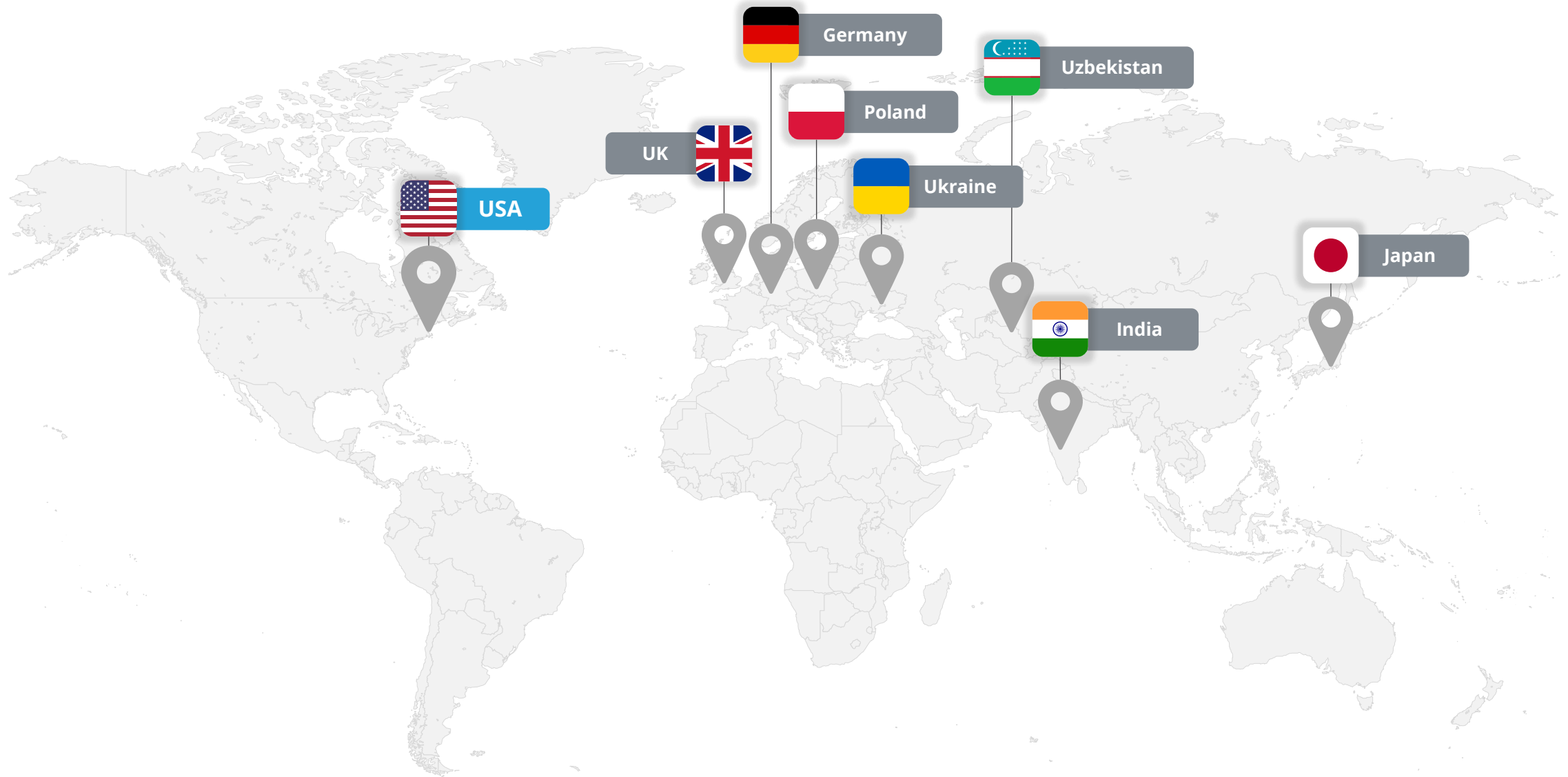

Driving Success with Siemens Technologies:

150+

Projects Delivered using Siemens PLM Components and technologies

80+

Clients benefiting from our Siemens technologies expertise

400+

Engineers with specialized Siemens expertise

Proven track record in:

Parasolid®

D-Cubed®

Kineo™

JT®

Solid Edge OEM

Teamcenter®

NX®

and more...

Parasolid
Geometric
Modeling

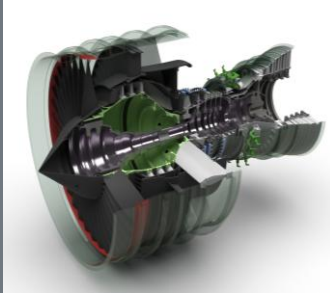

JT Open
Viewing and
collaboration

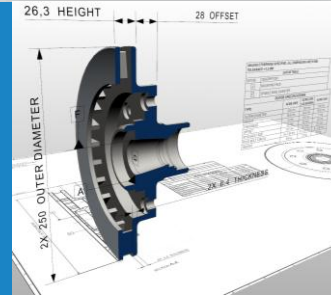

Geolus
Shape-based
search



D-Cubed
Parametric
design

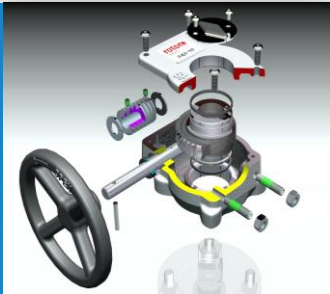

PLM Vis Web
Web 3D
graphics

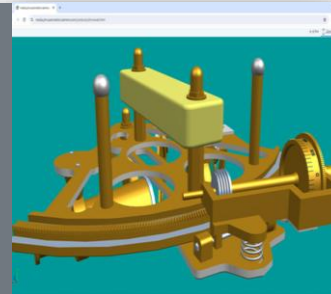

HOOPS
Rendering and
collaboration

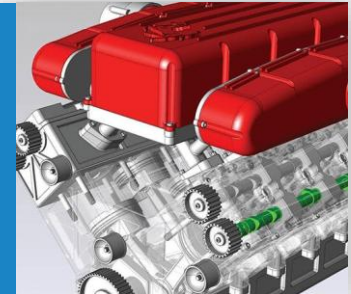

Kineo
Space and
motion design



Solid Edge
OEM
Mainstream
engineering



FEMAP
OEM
Simulation
toolkit

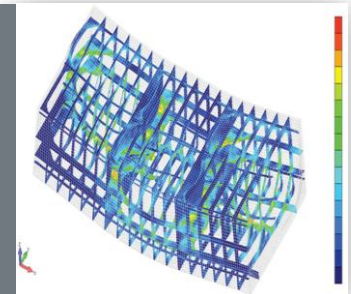

- How Parasolid's 1000+ modeling API's enable high-precision, scalable 3D applications
- Proven strategies for accelerating development and reducing complexity using PLM Components
- Introduction of AMC Bridge as Trusted Parasolid implementation partner
- Real-world success stories from AMC Bridge's 20+ Parasolid-based projects

Cloud-Based AEC Collaboration Platform — Parasolid-Driven Geometry Integration and Multi-Plugin Ecosystem Delivered with AMC Bridge

Key Challenges Addressed:

- **Cross-tool compatibility** for geometry exchange across multiple AEC authoring tools.
- **Reliable geometry handling** using Parasolid as the modeling backbone to mitigate format inconsistencies.
- **High-performance web visualization** requiring optimized rendering, mesh handling, WebGL performance tuning, and scene management.

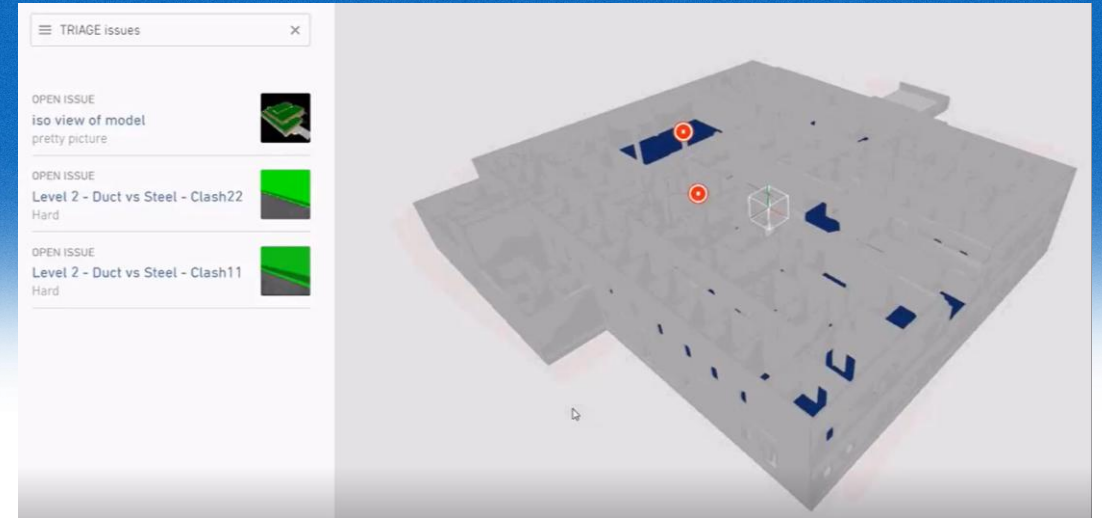

Business Benefits:

- **Consistent geometry exchange** through unified plugins across major design tools, reducing manual data transfer and rework.
- **Quick design iteration and consistency** – changes in one tool are immediately reflected everywhere else, updating visualizations and documentation on the fly.
- **Centralized issue tracking** integrated into the design ecosystem, supporting coordinated problem resolution.

Sheet Metal Manufacturing —
Parasolid-Centric CAD/CAM & Robotics
Solutions Delivered with AMC Bridge

Key Challenges Addressed:

- **Data integrity:** preserve 3D model detail and product metadata across import, unfold, and process planning.
- **Geometry reliability for sheet-metal:** manage bending/unbending operations and definitions with a dependable kernel backbone (Parasolid).
- **Robotic feasibility:** plan motion, model grippers and cells, and simulate end-to-end production steps.

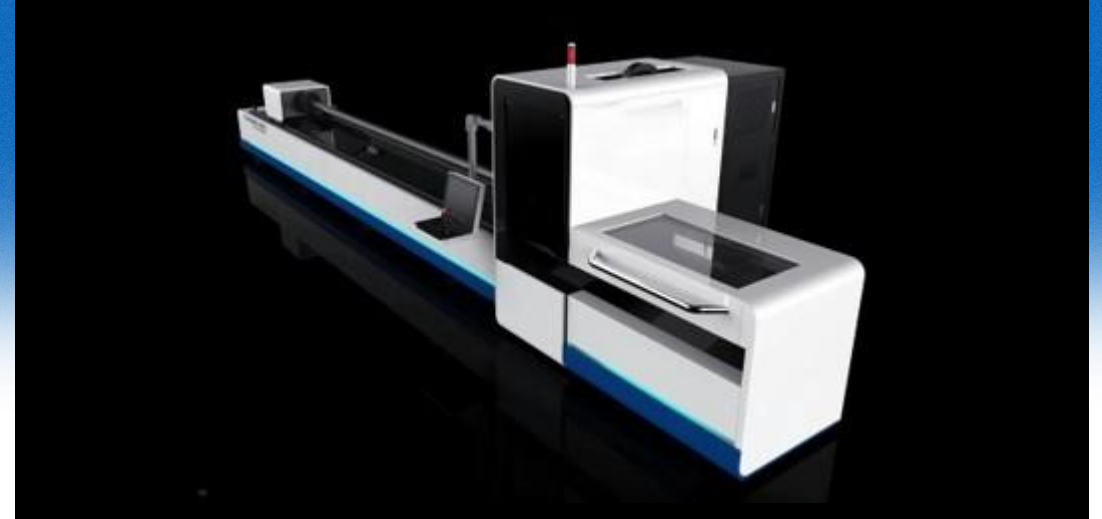

Business Benefits:

- **End-to-end coverage** from CAD import to robot execution and ERP oversight, minimizing tool fragmentation.
- **Higher data fidelity** by working directly with 3D models and avoiding lossy 2D conversions.
- **Scalable delivery model** and modular teams to expand capabilities (CAD add-ins, kernels, robotics, HMI) as needs evolve.

Generative Engineering Platform —
Parasolid-Powered and Scalable Desktop
Application Delivered with AMC Bridge

Key Challenges Addressed:

- **Iterative geometry stability** via **Parasolid**, providing dependable operations for automated modeling cycles.
- **Responsive UX under load:** background execution, solution caching, and intelligent selection keep workflows fluid.
- **Interoperability + visualization:** tech stack includes **HOOPS Exchange** and **HOOPS Visualize** to support CAD data workflows and high-quality rendering.

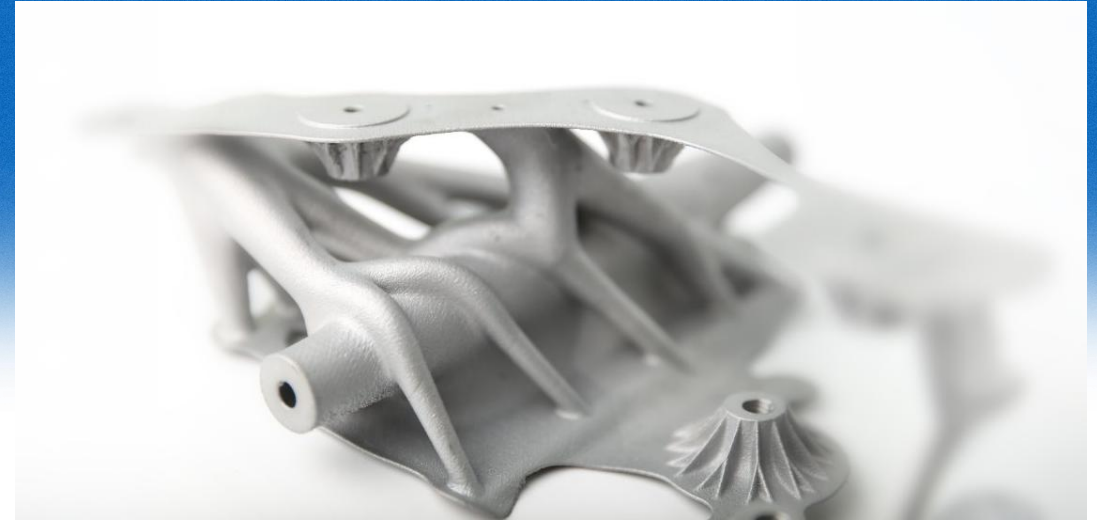

Business Benefits:

- **Accelerated design cycles** through automated growth and evaluation guided by technical DNA.
- **Quality and manufacturability:** FE results and additive manufacturing properties (e.g., support mass, overhang area) feed back into geometry decisions.
- **Extensibility:** customer-specific evaluative cells (including spreadsheet logic) enable design-to-cost and domain-specific checks within the same workflow.

Please share your feedback
after the webinar



AMC Bridge is a trusted software technology partner for engineering, manufacturing, and construction enterprises, whether they are actively pursuing AI-driven digital transformation or only beginning to recognize its potential. We help organizations to move beyond experimentation and achieve consistent ROI by delivering production-ready software and end-to-end solutions for their transformation journey.

We design, build, and integrate enterprise-grade software – applications, workflow extensions for CAD/PLM/BIM, data integrations, AI-enabled features – and deploy them with monitoring and lifecycle management so they remain reliable over time. Our services include assessing data readiness; preparing and unifying product and project data; and embedding AI into the workflows teams use every day. With 25+ years of industrial software expertise and deep ecosystem partnerships, including Aras, Autodesk, Bentley, Dassault Systemes, PTC, Siemens, Tech Soft 3D, and others, we empower enterprises to move confidently from experimentation to operational AI at scale.

**303 Wyman Street
Suite 300 Waltham,
MA 02451, USA**